

UHPS

Basic module with gasoline engine



Description

The basic module is the main item of the modular UHPS system and delivers 38 l/min at 100 bar. In combination with hose reel, branch pipe, water tank and basic frames, the system can be adapted flexibly to all requirements.

Benefits

Most effective extinguishing

- atomization of the water due to high pressure of 100 bar (1450 psi)
- precisely adapted nozzle design
- adjustable pattern: full to spray jet

Minimized water consumption

- output of 38 l/min (10 gpm)
- prevention of water damage

Superior foam quality / stability

- foam admixing system 0 to 6 %
- foam attachment for fog gun

Large effective operating range

- 10 m (33 ft) effective throwing range
- 60 m (197 ft) buckle safe hose

Simple / safe operation

- fixed setting of pressure and output
- thin, lightweight and nevertheless very robust hose
- ergonomic fog gun
- continuous water supply
- refilling of water tank during operation

Applications

- rapid intervention vehicles
- small extinguishing vehicles

Fields of application

- first attack
- car fires
- forest fires
- pool fires (liquid fires)

UHPS

Basic module with gasoline engine

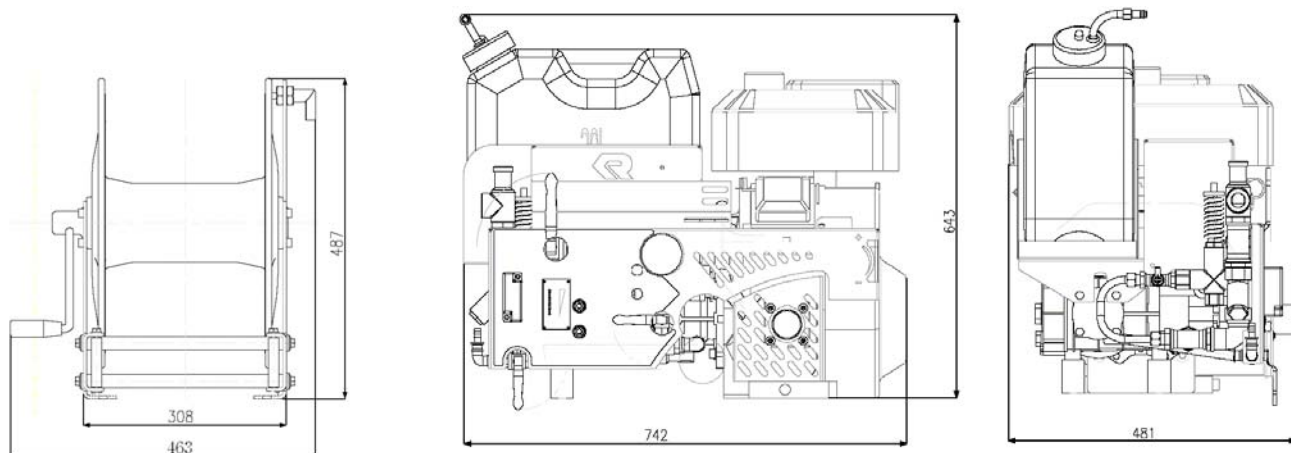

Dimensions of hose reel and basic module (in mm)



Control panel



Example of installation

Technical data

Engine	Briggs&Stratton 2-cylinder, 4-stroke gasoline engine, 480 cm ³ , 11,8 kW (16 PS) at 3600 1/min 12 V electric starter with manual rope recoil starter, fuel tank 8,5 l (2,25 gal)
Extinguishing system	high pressure plunger pump with 38 l/min at 100 bar (10 gpm at 1450 psi), foam admixing system 0 – 6 %, filter element, manometer with glycerine damping
Hose, Hose reel	60 m high pressure hose (197 ft), hose reel with window, brake and catch
Fog gun	ergonomically formed fog gun with piston handgrip, Infinite adjustment of full to spray jet <ul style="list-style-type: none">▪ standard branch pipe: foam barrel detachable▪ combined branch pipe: foam barrel integrated
Weight	<ul style="list-style-type: none">▪ UHPS basic module: 95 kg (209,4 lbs), unfilled▪ Standard foam canister 20l: 20 kg (44,1 lbs)▪ Manual hose reel: 52 kg (114,6 lbs), (hose reel, 60m high pressure hose, standard branch pipe)
Dimensions	<ul style="list-style-type: none">▪ UHPS basic module: LxWxH = 742 mm x 481 mm x 643 mm LxWxH = 29,2 in x 18,9 in x 25,3 in▪ hose reel manual: LxWxH = 463 mm x 460 mm x 487 mm LxWxH = 18,2 in x 18,1 in x 19,2 in▪ hose reel electric: LxWxH = 545 mm x 460 mm x 487 mm LxWxH = 21,5 in x 18,1 in x 19,2 in

Contact

Rosenbauer International AG
Paschinger Straße 90
4060 Leonding, Austria
Tel.: +43 732 6794-0
Fax: +43 732 6794-91

www.rosenbauer.com

www.facebook.com/rosenbauergroup

Text and illustrations are not binding. The illustrations may show optional extras only available at extra charge. Rosenbauer retains the right to alter specifications and dimensions given herein without prior notice.

KR161
2013-06_RWeb