



# STINGER

High Reach Extendable Turret

ARFF vehicles and industrial fire fighting vehicles



# Fire fighting on airports.

## STINGER for aircraft rescue and fire fighting (ARFF) vehicles.

The STINGER High Reach Extendable Turret (HRET) has been developed by Rosenbauer with state-of-the-art design and production methods, keeping in mind the unique needs of airport fire fighting services. It meets and exceeds the fire fighting challenges given by the latest passenger and cargo planes (A380, B787). The movement range of boom, turret and the absolutely unique piercing tool covers all required attack positions. The horizontal rotation of the HRET is a total of 60° (30° left and right) without the need for outriggers.

### Pre-programmed positions

Three pre-programmed and customizable attack positions are available. Each position can be selected by individual controls, manual control can override anytime the automatic mode at operator's choice. An additional Auto-STOW mode is provided to retract the system on demand.

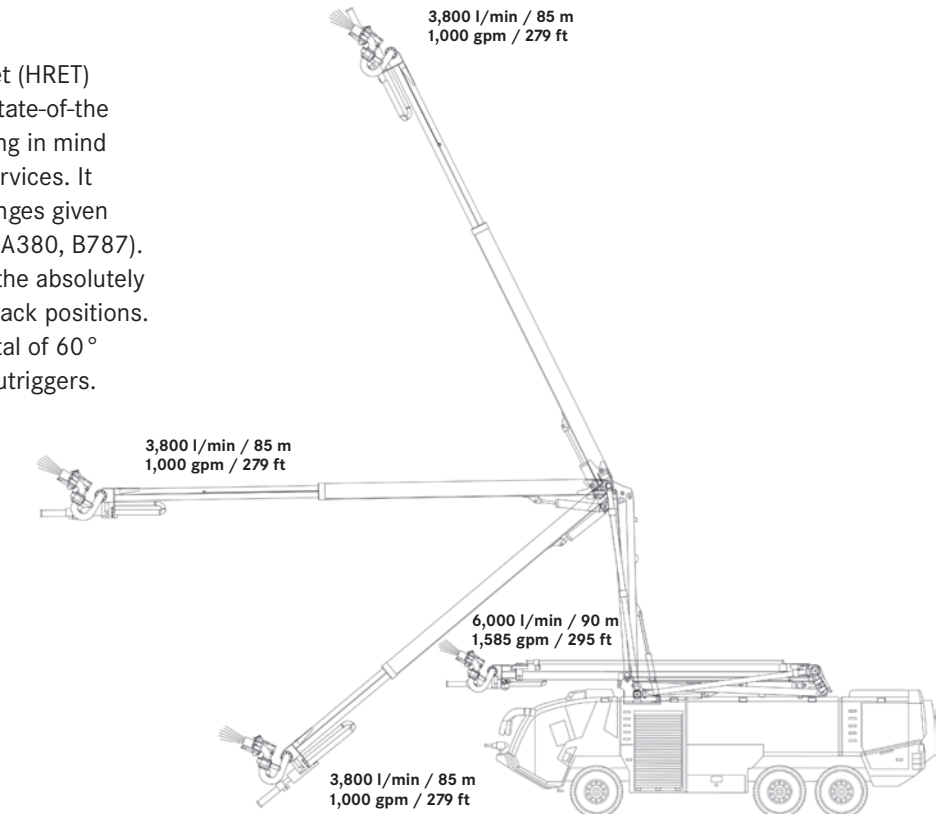

### Impressive extinguishing performance

#### Rosenbauer RM65 Turret

The throw range at rated 6,000 lpm (1,585 USgpm) in stowed position corresponds with the high output performance of the standard Rosenbauer RM60 roof turret. It also provides a max. throw range of 90 m (295 ft) to meet the requirements of CAT 10 airports! In elevated position of up to 16.5 m (54 ft) flow rate of 3,800 lpm (1,000 USgpm) is provided. The RM65 has a movement range of 180° for both, horizontal and vertical direction. Furthermore, the nozzle has an infinite stream adjustment from straight to spray stream. In addition two flow rates are available, usually 50% and 100% output. Option: The Rosenbauer turret with ChemCore option is available to provide a concentric powder stream in the water stream, greatly improving the throw range for dry chemical powder. The powder is delivered to the nozzle through a telescoping pipe with minimum friction loss and is insensitive to clogging.

#### Piercing Tool

The piercing tool has an output of 1,000 lpm (264 USgpm).





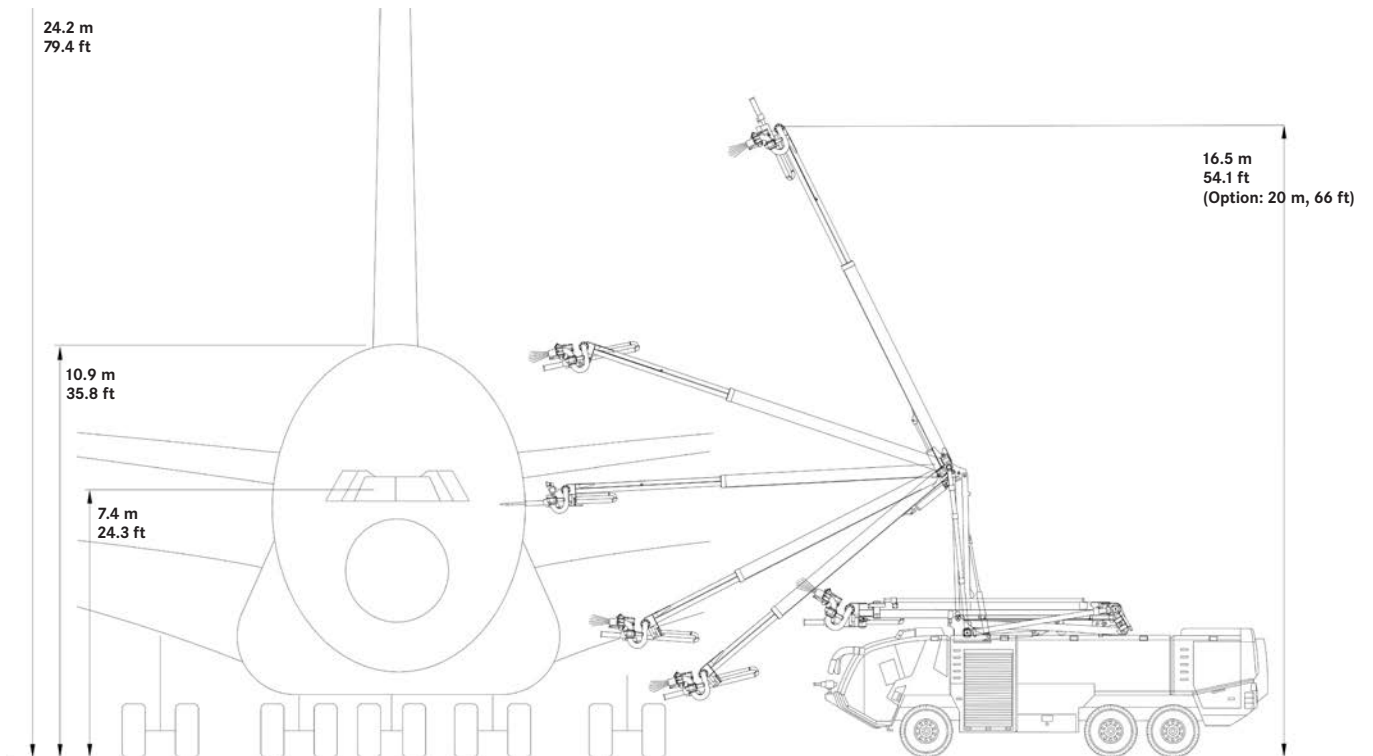

**Everything in view**

Cameras can be attached on the turret with a choice of color camera and/or FLIR camera (infrared) systems including corresponding recording devices. Alternatively, the color camera can be mounted on the piercing tool itself to

provide best control in remote upper or lower aircraft fuselage positions. Ergonomically located displays in the cabin allow operation from driver or turret operator position.

The throw range at rated 6,000 lpm (1,585 USgpm) in stowed position corresponds with the high output performance of the standard Rosenbauer RM60 roof turret.



### Efficient interior attack with the piercing tool

The Rosenbauer piercing tool has a hydraulic dual drive:

- The vertical rotation range is 180 ° overall and enables the precise placement of the piercing tool with its unique docking sensor system.
- With linear motion of 520 mm (20.5"), the piercing tip penetrates with ease through the strongest of composite materials now being used on the latest aircraft. The flow rate through the piercing nozzle is 1,000 lpm (264 USgpm).

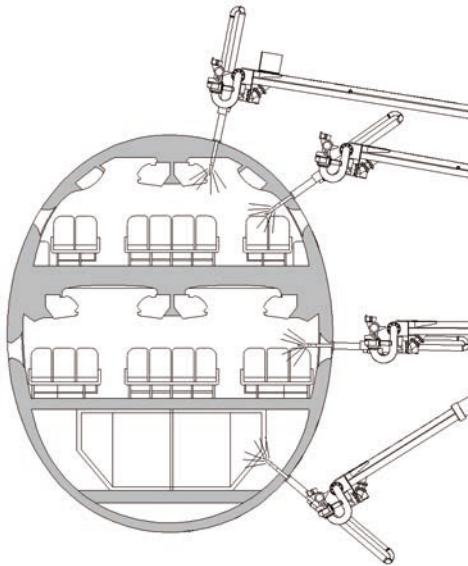

The unique and patented piercing actuation overcomes all known limitations of conventional designs and a variety of materials can be easily and precisely penetrated without sliding or jamming. GLARE and aluminum sheet of 4 mm (0.16"), steel sheet of 2.5 mm (0.1") and GRP of up to 12 mm (0.5") are no match for the advanced penetrating device, operating at a pressure of 210 bar (3,000 psi).

### Ergonomic one-hand operation

The single STINGER joystick controls the movements of the boom, RM65 turret and piercing tool.

Additional pre-programmed controls, Auto-STOW and powder selection controls are provided. Optional camera controls are also located in an ergonomic position close to the main joystick.

The overall vehicle fire fighting system status is shown on the main vehicle display. It includes the status of the water, water/foam discharge at the main turret as well as the agent levels of water and foam tanks.



**Training for emergency situations**

The optional Rosenbauer STINGER simulator is a real time training device to fine tune the skill of operators, providing a very cost effective training solution.

The simulation can be installed on an industry standard laptop with high-resolution screen and operated with original operating controls of the STINGER.

The following models have been made available:

- Airbus A380, currently the largest passenger airplane in the world
- MD11, popular cargo plane with tail engine position
- Virtual training wall on which the precise positioning of the piercing tool can be practiced.



The simulator allows setting real environmental conditions such as driver’s position left/right, speed display in kph or mph, weather conditions (sun, cloud, wind, rain, mist, snow) and lighting conditions (day/night).

The simulation also allows different perspectives (from the point of view of the driver, co-driver position, side view or top view). Actual foam conditions during discharging operation are realistically shown during the training session.





# Fire fighting in industrial application.

## STINGER for industrial fire fighting vehicles.

Fire fighting efficiency can be greatly improved through elevated fire attack positions—the Rosenbauer STINGER provides up to 16.5 m (54.1 ft) vertical reach (Option: 20 m / 66 ft).

Operating the STINGER through a radio remote control unit minimizes manpower needs and provides full flexibility for best overview at the fire ground.

In areas with high radio interference, the device can be tether controlled through a secure cable connection.

The STINGER for industrial fire fighting vehicles is equipped with a turntable for 360° continuous rotation. Extinguishing agent and hydraulic and electrical lines are routed through a central swivel.

Two hydraulic outriggers under the turntable ensure safe operation in any position. A flow rate of up to 4,500 lpm (1,200 USgpm) can be achieved.

In the stowed position, full turret performance can be achieved without outriggers.

Option: Turret for concentric dry chemical injection for optimized fire fighting capabilities available.





# STINGER

## High Reach Extendable Turret



### Technical Data

Typ	STINGER for ARFF vehicles	STINGER for industrial vehicles
Max. working height	16.5 m (54 ft) Option: 20 m (66 ft)	16.5 m (54 ft) Option: 20 m (66 ft)
Max. range (from middle of turntable)	11.4 m (37.4 ft) at 20 m Stinger: 13.8 m (45 ft)	11.4 m (37.4 ft) at 20 m Stinger: 13.8 m (45 ft)
Rotation angle	+/- 30 ° (left/right)	360 ° endless
Operation	Joystick (1-hand operation)	Radio remote control
Pre-programmed positions	3 positions + stow position	Auto-stow
<b>Flows</b>		
Full amount in stowed position	6,000 lpm (1,585 USgpm)	6,000 lpm (1,585 USgpm)
Reduced flow in stowed position <sup>1)</sup>	3,000 lpm (793 USgpm)	3,000 lpm (793 USgpm)
Full amount out of stowed position	3,800 lpm (1,000 USgpm)	4,500 lpm (1,200 USgpm)
Reduced flow out of stowed position <sup>1)</sup>	1,900 lpm (500 USgpm)	2,250 lpm (595 USgpm)
Rotation angle turret	+/- 90 ° (left/right)	+/- 90 ° (left/right)
Vertical movement turret	+/- 90 ° (up/down)	+/- 90 ° (up/down)
Flow piercing tool	appr. 1,000 lpm (264 USgpm)	appr. 1,000 lpm (264 USgpm)
Flow dry chemical	15 kg/s (33 lbs/s)	15 kg/s (33 lbs/s)

<sup>1)</sup> Position can be programmed (standard 50%)

### Contact

Rosenbauer International AG  
Paschinger Straße 90  
4060 Leonding, Austria  
Tel.: +43 732 6794-0  
Fax: +43 732 6794-83  
office@rosenbauer.com

[www.rosenbauer.com](http://www.rosenbauer.com)